

Atlas Copco Surface drill rigs

FlexiROC T45

Technical specification



FlexiROC T45 is intended for construction sites, aggregate and limestone quarries. The main components are:

- Crawler type two speed undercarriage with track oscillation system
- Caterpillar turbo charged diesel engines
- Atlas Copco screw type compressor
- Hydraulic cooling system for 50 °C ambient temperature
- Combined warning sound and warning light
- Fixed boom system/folding boom system
- Hydraulic chain feed system with hose guide
- Hydraulic rock drill COP 3060/COP 2560
- Rock drill lubrication system
- COP Logic
- Toe-hole drilling system
- Carousel type rod handling system
- Hydraulic double drill steel support with movable dust collector hood
- Double hose drum
- Dust Collection system

Hole range			
Recommended hole range			
FlexiROC T45 fixed boom	T51, T60	89-140 mm	3 ½" - 5 ½"
FlexiROC T45 folding boom	T45, T51	89-127 mm	3 ½" - 5"
Hydraulic rod handling system for max hole depth, with 4,2 m (14') extension rods and a 6,1 m (20') starter rod			
FlexiROC T45 fixed boom	T51, T60	35 m	115'
Hydraulic rod handling system for max hole depth, with 3,6 m (12') extension rods and a 4,2 m (14') starter rod			
FlexiROC T45 folding boom	T45, T51	29 m	95'

Specifications

Engine

Caterpillar turbo charged, diesel engine, CAT C9.3/ CAT C9, Tier 4/Stage IIIB and Tier 3/Stage IIIA

- Power rating at 1900 rpm 242 kW 325 HP

Carrier

- Trimming speed 3,4 km/h 2,1 mph
- Track oscillation $\pm 10^\circ$
- Ground clearance 405 mm 16"

Feed

FlexiROC T45-10

Hydraulic chain driven aluminium feed with hose guide and double drill steel support with movable lower guide/dust hood

- Feed extension 1 900 mm 6'3"
- Feed rate, max 0.9 m/s 177 ft/min
- Feed force, max 40 kN 8 992 lbf
- Tractive pull, max 50 kN 11 240 lbf
- Total length 9 500 mm 31'
- Travel length 5 520 mm 18'1"

FlexiROC T45-11

Hydraulic chain driven steel feed with hose guide and double drill steel support with moveable lower guide/dust hood

- Feed extension 1 150 mm 3'9"
- Feed rate, max 0.9 m/s 177 ft/min
- Feed force, max 20 kN 4 496 lbf
- Tractive pull, max 30 kN 6 744 lbf
- Total length 7 700 mm 25'3"
- Travel length 4 610 mm 15'2"

Dust collector DCT 200

- Filter area 20 m² 215 sq.ft
- Number of filter elements 20 pcs
- Suction capacity at 500 mm wg 540 l/s 1 144 cfm
- Suction hose diam 127 mm 5"
- Cleaning air pressure, max 7.5 bar 109 psi
- Cleaning air consumption 2-4 l/pulse 0.06 - 0.12 cu.ft/pulse

Air conditioner

- Refrigerant R134a
- Cooling capacity 5,5 kW
- Fan suction capacity 125 l/s 265 cfm

Electrical system

- Voltage 24 V
- Batteries 2 x 12 V, 185 Ah
- Alternator 28 V, 105 Ah
- Work lights LED type, front 4 x 3500 Lumen
- Work lights LED type, rear 2 x 3500 Lumen
- Work lights LED type, feed 2 x 5300 Lumen
- Warning lamp and reverse buzzer

Safety cabin

- ROPS and FOPS approved with rubber vibration dampers
- 2 x wipers with washer
- Clear laminated glass (front and roof windows)
- Clear toughened glass (side and rear windows)
- Fully adjustable operator's seat
- Adjustable foot rest
- Cabin light
- Rig inclination indicator
- Rear view mirror
- Fire extinguisher, 6 kg (13 lbs) dry chemical type ABE class III type
- Outlet socket, 24 V
- Prepared with speakers for CD-radio or DVD radio
- Combined front mounted platform/tool box
- Electric combined engine/inclination/hole depth instrument in main computer display

Compressor

Atlas Copco C146-07, screw type compressor

- Working pressure, max 12 bar 174 psi
- FAD at normal working pressure 223 l/s 472 cfm

Hydraulic system

Hydraulic oil cooler

- Max ambient temperature 50°C 122°F

Pumps at 1900 rpm

- Axial piston pump (1) 160 l/min 42.3 US gal/min
- Gear pump (2) 120 l/min 31.7 US gal/min
- Gear pump (3) 40 l/min 10.6 US gal/min
- Gear pump (4) 40 l/min 10.6 US gal/min
- Gear pump (5) 40 l/min 10.6 US gal/min

Return and drainage filters

- Filtration rate 10 µm absolute

Volumes

- Hydraulic oil tank 100 l 36.4 US gal
- Hydraulic system, total 240 l 63.4 US gal
- Compressor oil 52 l 13.7 US gal
- Diesel engine oil 32 l 8.4 US gal
- Diesel engine, cooling water 75 l 19.8 US gal
- Diesel engine, fuel tank 400 l 105.7 US gal
- Traction gear 3 l 0.8 US gal
- Lubrication tank (ECL) 23 l 6.1 US gal

Hydraulic rock drill

Rock drill	Drill rig	Impact power	Impact rate, max	Hydraulic pressure, max	Torque, max	Weight approx
COP 2560	FlexiROC T45-11	25 kW 33.5 HP	44 Hz	230 bar 3 335 psi	1 555 Nm 1 147 lbf/ft	187 kg 412 lb
COP 2560 EX						249 kg 549 lb
COP 3060	FlexiROC T45-10	30 kW 41 HP	50 Hz	240 bar 3 481 psi	2 450 Nm 1 807 lbf/ft	315 kg 694 lb
COP 3060 EX						355 kg 783 lb

Transport dimensions

Height and length		
Fixed boom		
Height (H1)	3 200 mm	10' 6"
Length (L1)	10 700 mm	35' 2"
Folding boom		
Height (H2)	3 200 mm	10' 6"
Length (L2)	13 300 mm	43' 8"

Feed dumped (fixed boom)



Feed dumped (folding boom)



Dimensions and weight



Weight

Standard unit excluding all options and drill steel		
FlexiROC T45 fixed boom	19 600 kg	43 200 lb
FlexiROC T45 folding boom	17 500 kg	38 600 lb

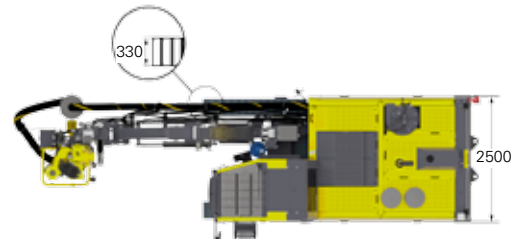

Selection of optional equipment

Carrier

- Hydraulic support leg
- Hydraulic winch, radio remote controlled with towing eye and wire guides
- Electric refuelling pump
- Track chains with single/triple grouser pads
- Extra LED work lights
- Water mist system, 225 l

Safety cabin

- Clear laminated glass (front and roof windows)
- Tinted toughened glass (side and rear windows)
- Wiper for right hand side window

- Sun shade kit (rear side and rear windows)
- Radio/CD
- Reverse camera

Feed

- Wide feed foot
- TAC guide tube guides for drill steel support
 - TAC 64 mm for 64 mm guide tube
 - TAC 76 mm for 76 mm guide tube
 - TAC 87 mm for 87 mm guide tube

Hole measuring systems

- Laser receiver upgrading kit
- GPS compass for parallel holes

Lubrication

- Central lubrication system, type HydroScand
- Thread greasing devise ECG (with oil)
- Thread greasing device, brush type (with grease)
- PAR Oil S
- PAR Oil M

Environment conditions

- Diesel driven engine heater
- Artic hydraulic oil, VG 32
- Tropical hydraulic oil, VG 68
- Biological hydraulic oil, VG 46

Delivered equipment, not mounted

- Gas charging equipment for rock drill
- First 50 hours service kit for compressor
- Conversion kit T45
- Conversion kit T51
- Conversion kit T60
- ROC Manager with bench plan
- RCS service tool box
- Electrical tool kit

Rock Drill control system

- Progressive COP Logic

Coverage areas

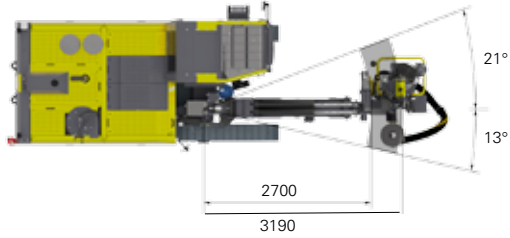

Horizontal reach (mm) fixed boom



Vertical reach (mm) fixed boom

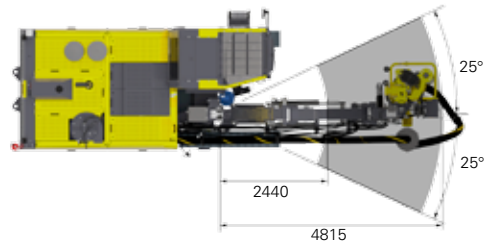

Horizontal reach (mm) folding boom

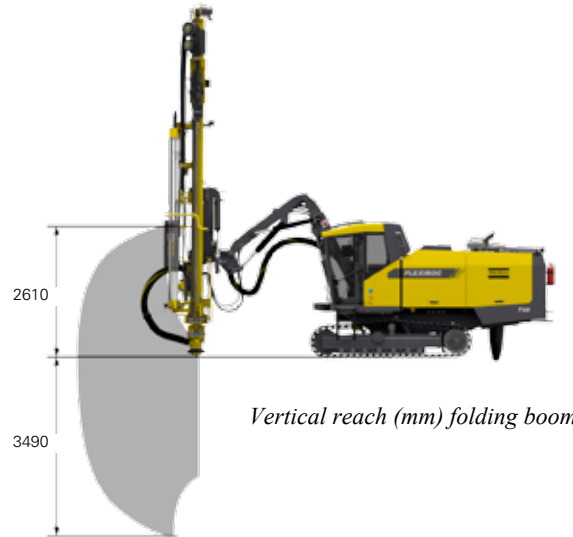

Vertical reach (mm) folding boom

Feed swing angles

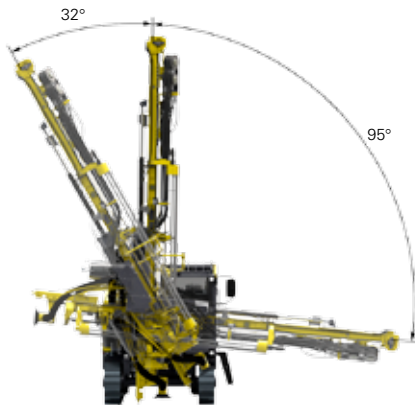

Valid for both fixed and folding boom